

Features

- Direct operated valve
- High degree of pressure stability
- Safe operation
- Precise pressure adjustment
- Porting NG 6 according to DIN 24340
- Maximum pressure setting with lock nut

Pressure relief valves	Type DV700
NG 6 up to 700 bar	up to 25 l/min



Application

- as cartridge
- as modular valve with one or two cartridges

Pressure relief valves are direct operated seated valves with dumping piston. They are used to limit the pressure in a hydraulic system.

Technical data

Hydraulic fluid	Mineral oil according to DIN 51524 (other fluids on request)
Fluid temperature range	NBR: -30 to 80 °C FPM: -20 to 80 °C
Ambient temperature range	-30 to 50 °C
Viscosity range	5 to 400 mm ² /s
Porting	NG 6 according to DIN 24340 / ISO 4401 / CETOP RP 121 H
Operating pressure max. connection P, A, B	700 bar
Pressure admissible max. connection T	350 bar
Flow rate max.	25 l/min
Filtration	according to NAS 1638, class 6 or ISO/DIN 4406 15/12
Weight	see dimension drawings
Material / surface treatment	housing: steel, galvanized, chromated cartridge: steel corrosion resistant adjusting knob: plastic

Pressure relief valves	Type DV700
NG 6 up to 700 bar	up to 25 l/min

Function and design

The valve consist of a cartridge (1), seat (2), taper (3) with dampening piston (4), spring (5), adjusting spindle (6) and lock nut (7).

The system pressure can be set to the required pressure via the adjusting spindle.

The spring pushes the taper onto the valve seat. The system pressure in the P-line acts on the taper.

If the pressure raises above the set pressure via the spring the taper opens and the hydraulic medium flows from port P to tank.

Because the pressure limitation in a system is a dynamic event the taper is fitted with a dampening piston.

This piston dampens the movement during opening and closing of the taper and therefore a stable pressure limitation is achieved.

To achieve a good pressure adjustment and p-Q characteristic over the entire operation range the pressure range was split into two. A flat p-Q curve is achieved by clever deflection of the flow, hence using the dynamic energy of the flow.

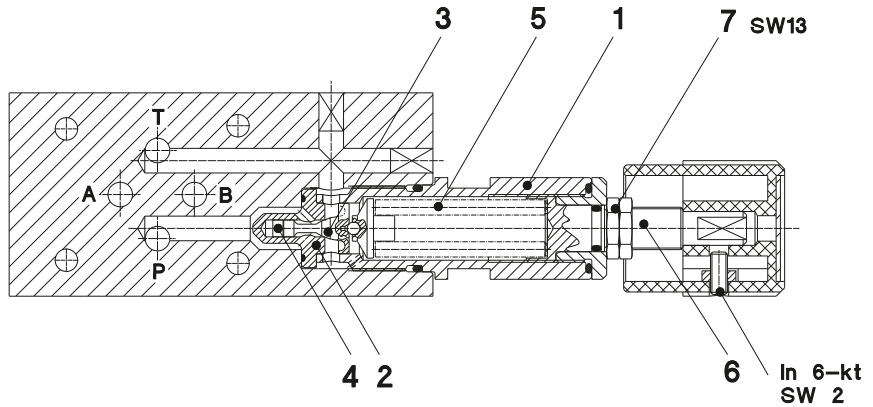

Characteristics of modular valves

measured at $\nu = 32 \text{ mm}^2/\text{s}$, $T = 40^\circ\text{C}$

Setting pressure

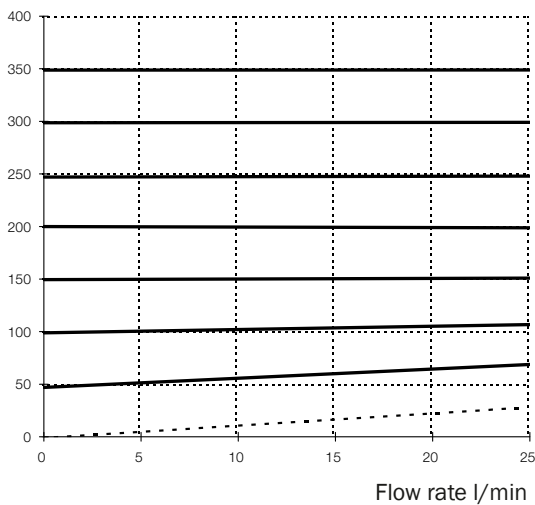

... = min. setting pressure
max. setting pressure 350 bar

Setting pressure

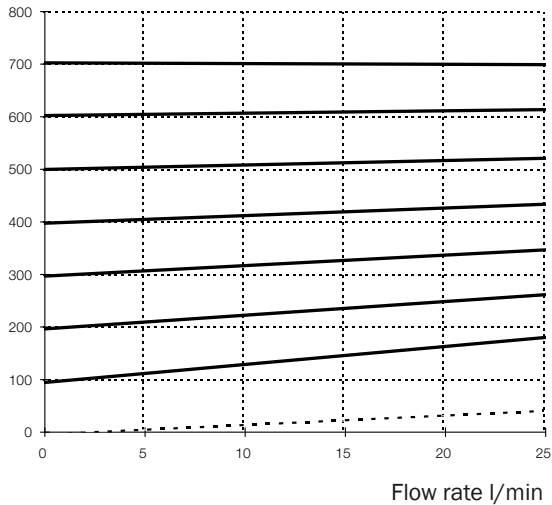

... = min. setting pressure
max. setting pressure 700 bar

Screw-in cartridge (Type DV700-6-E ...)

Design revision A, Weight 0,2 kg

Symbol

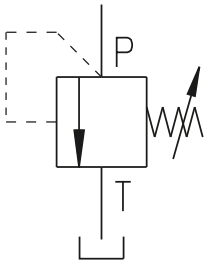

Dimension drawing

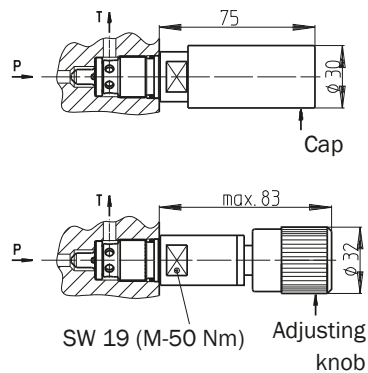

Bore dimension

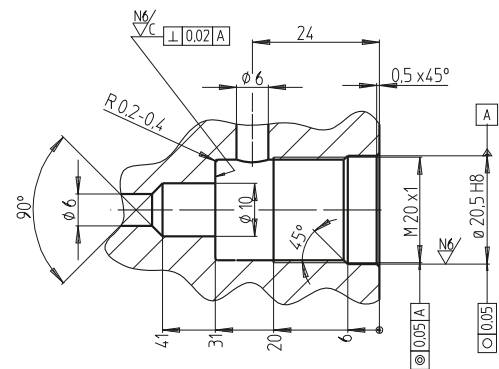

Article no.	P [NBR]	V [FPM]
350 bar	50956	52030
700 bar	50952	52028

Intermediate plate valves

from P to T (Type DV700-6-P ...)

Design revision A, Weight 1,6 kg

Symbol

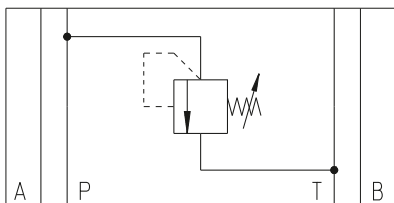

Dimension drawing

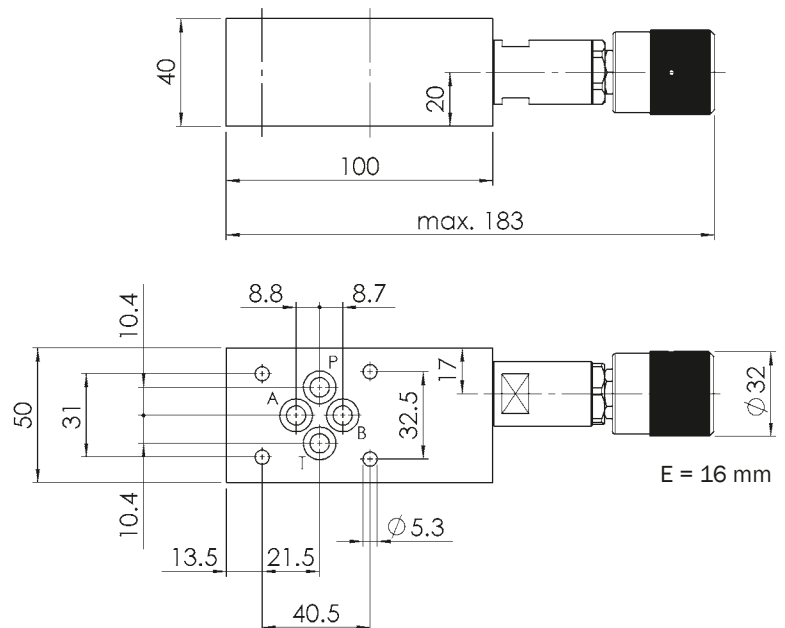

Article no.	P [NBR]	V [FPM]
350 bar	50968	52015
700 bar	49610	52018

from B to T (Type DV700-6-B ...)

Design revision A, Weight 1,6 kg

Symbol

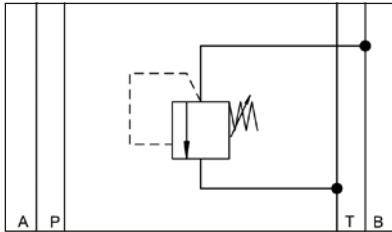

Dimension drawing

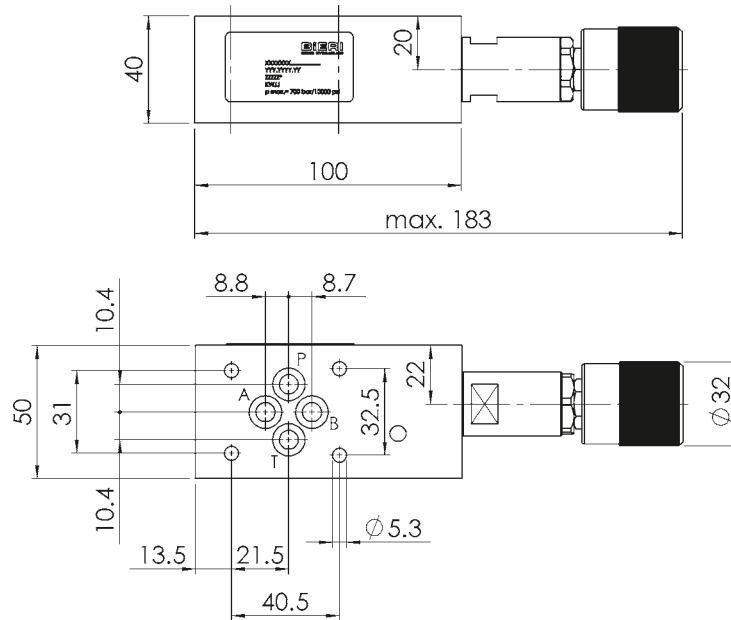

Article no.	P [NBR]	V [FPM]
350 bar	50972	52022
700 bar	50971	52020

Pressure relief valves	Type DV700
NG 6 up to 700 bar	up to 25 l/min

from A to T and B to T (Type DV700-6-AB ...)
 Design revision A, Weight 2,0 kg

Symbol

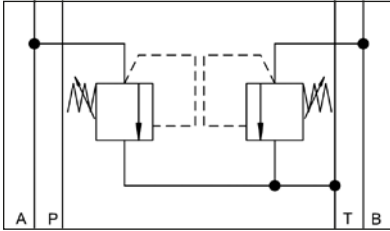

Dimension drawing

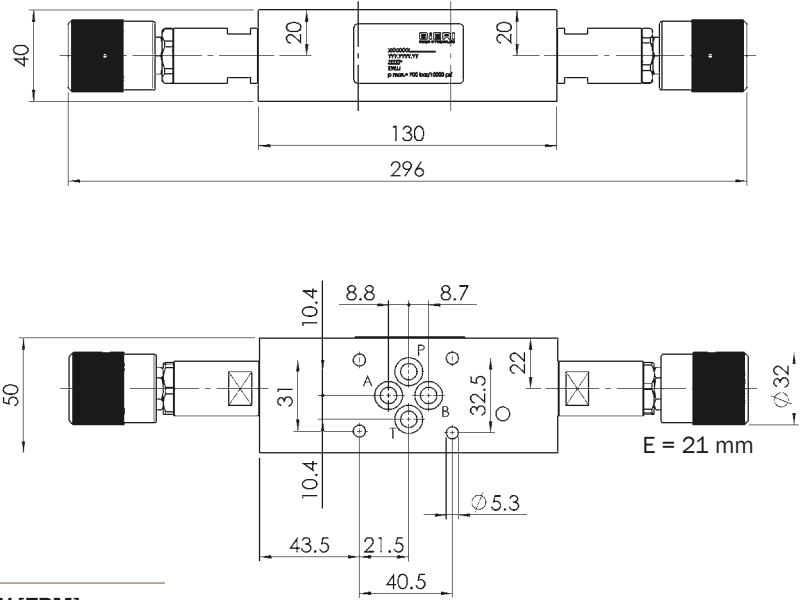

Article no.	P [NBR]	V [FPM]
350 bar	50979	52024
700 bar	50976	52023

Pressure relief valves
NG 6 up to 700 bar

Type DV700
up to 25 l/min

from P to T and A to T (Type DV700-6-PA ...)
 Design revision A, Weight 2,0 kg

Symbol

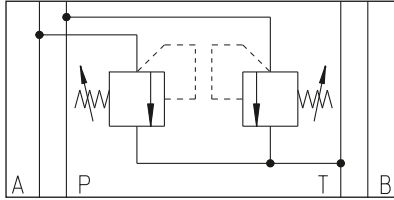

Dimension drawing

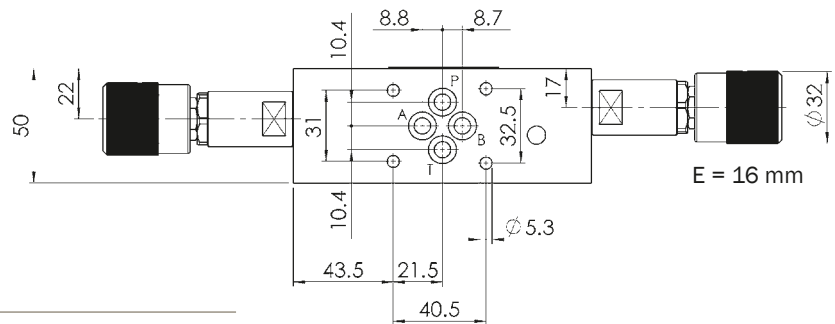
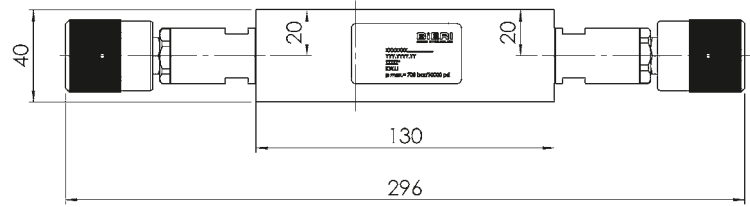

Article no.	P [NBR]	V [FPM]
350 bar	50975	52026
700 bar	50500	52025

Pressure relief valves	Type DV700
NG 6 up to 700 bar	up to 25 l/min

Ordering code: Example

DV	700	-	6	-	P	-	350	-	P	-			00
----	-----	---	---	---	---	---	-----	---	---	---	--	--	----

Pressure relief valve

Type DV700

Size 6

Pressure relief	E	Cartridge
		Modular subplate
		from - to:
	P	P - T
	A	A - T
	B	B - T
	AB	A - T and B - T
	PA	P - T and A - T

max. setting valve	350 bar
	700 bar

Seals	P (NBR)
	V (FPM)

Special design01 ... 99
(00 for standard)**Part index**Please leave it blank
(small letters a-z; different letters
do not effect interchangeability)**Design revision (AS)**see dimension drawings
(capital letters A-Z; identical letters
equal same connecting dimensions)**Accessories**

For each valve the following is included:
4 pieces O-Rings 9,25 x 1,78 mm
90°ShA part no. 900195
Adjusting knob mounted
Cap in addition

Tie bolts / fixation screws and subplates
see technical data sheet AP / RP

Operating instructions see BA-BV700

As we are constantly improving our products,
Bieri reserves the right to make changes to the
technical specification without prior notice.

DV700-EN-1008

Bieri Hydraulik AG
Könizstrasse 274
CH-3097 Liebefeld/Switzerland
Tel. +41 31 970 09 09
Fax +41 31 970 09 10
sales@bierihydraulics.com

BIERI
SWISS HYDRAULICS